

Mechanical Engineering

# Waste Pulper LMC

for production of  
pumpable suspensions



Maschinenbau Lohse GmbH  
Unteres Paradies 63 · 89522 Heidenheim  
phone +49 7321 755-79  
sales@lohse-gmbh.de  
www.lohse-gmbh.de

## Application

Waste pulper serve to separate a pumpable medium from organic waste and water. The waste is pulped and dissolved in the waste pulper. By means of a heavy materials dirt trap the rejected materials are separated from the accepted medium.

## Design

- stable bearing assembly on the top
- closed tank
- centrally positioned dirt trap
- pulping tackle with removable wear parts
- components to optimize the dispersing process
- spiral conveyor to remove the heavy rejected materials

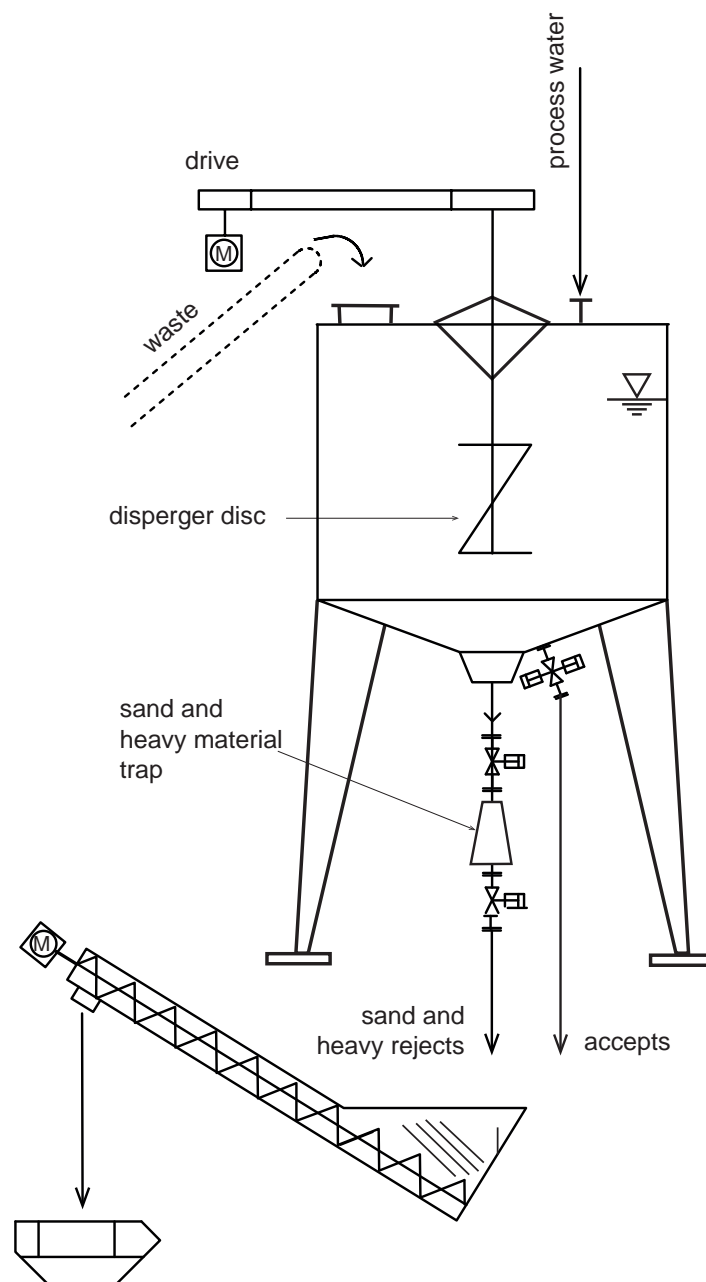

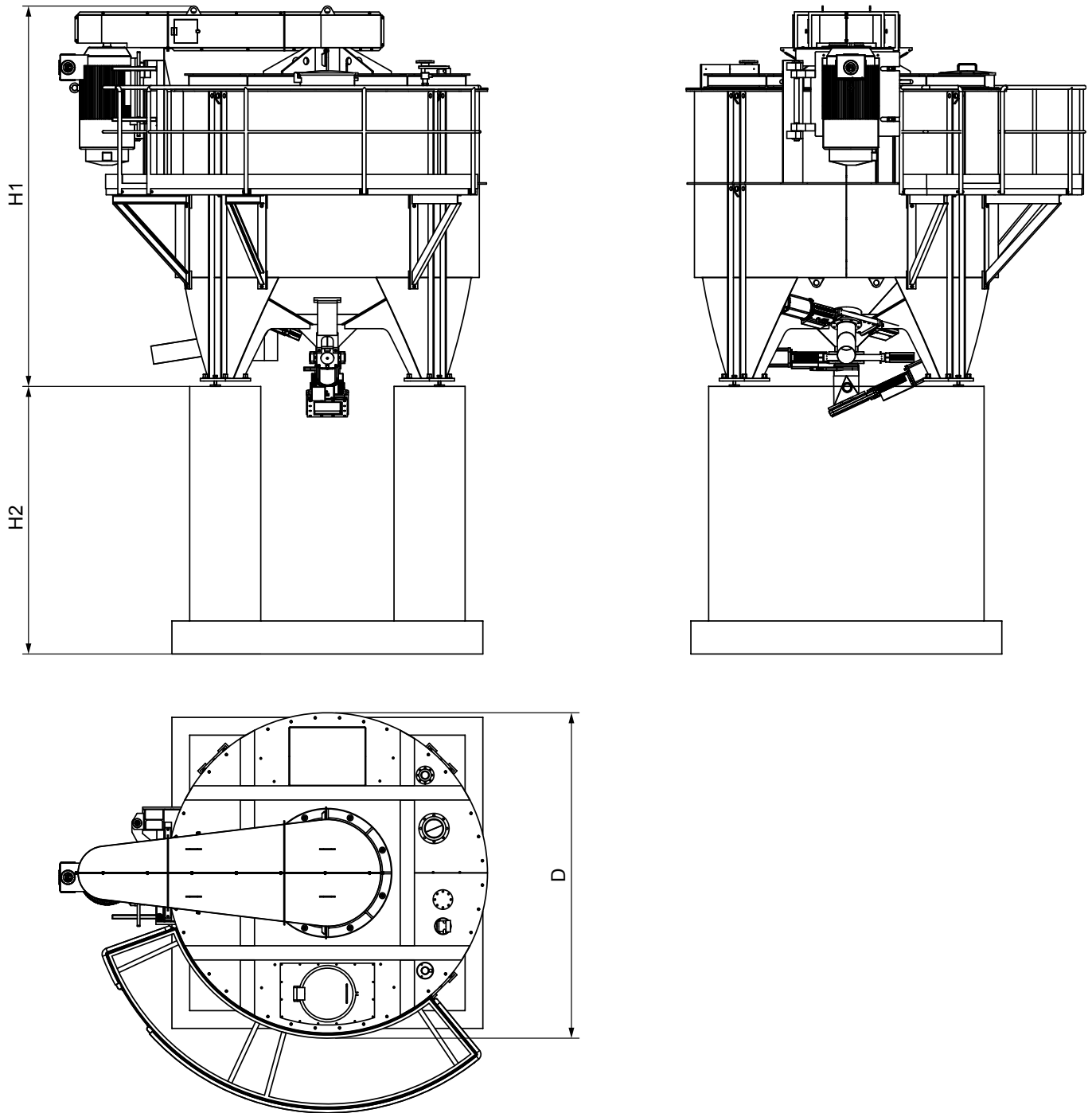

size		LMC4	LMC6	LMC8	LMC10	LMC12	LMC16	LMC20	LMC23	LMC26	LMC32
usable volume	m <sup>3</sup>	4	6	8	10	12	16	20	23	26	32
diameter D	mm	2250	2250	2900	2900	3400	3400	3800	3800	3800	3800
tank height H1	mm	–	–	3650	3950	4150	4670	5050	5320	5590	6120
base height H2	mm	–	–	variable							
complete height H1 + H2	mm	5500	6000	–	–	–	–	–	–	–	–
motor	kW	37	55	90	110	132	160	200	225	280	300
tare weight	kg	4800	5400	8600	10000	12000	12000	20000	20000	22000	22500

LMC4 + LMC6 with base of steel construction; from LMC8 with base of concrete



*LMC4 + LMC6 with base of steel construction*



*from LMC8 with base of concrete*

