

Valves of stainless steel

Dirt Traps RSL

of stainless steel

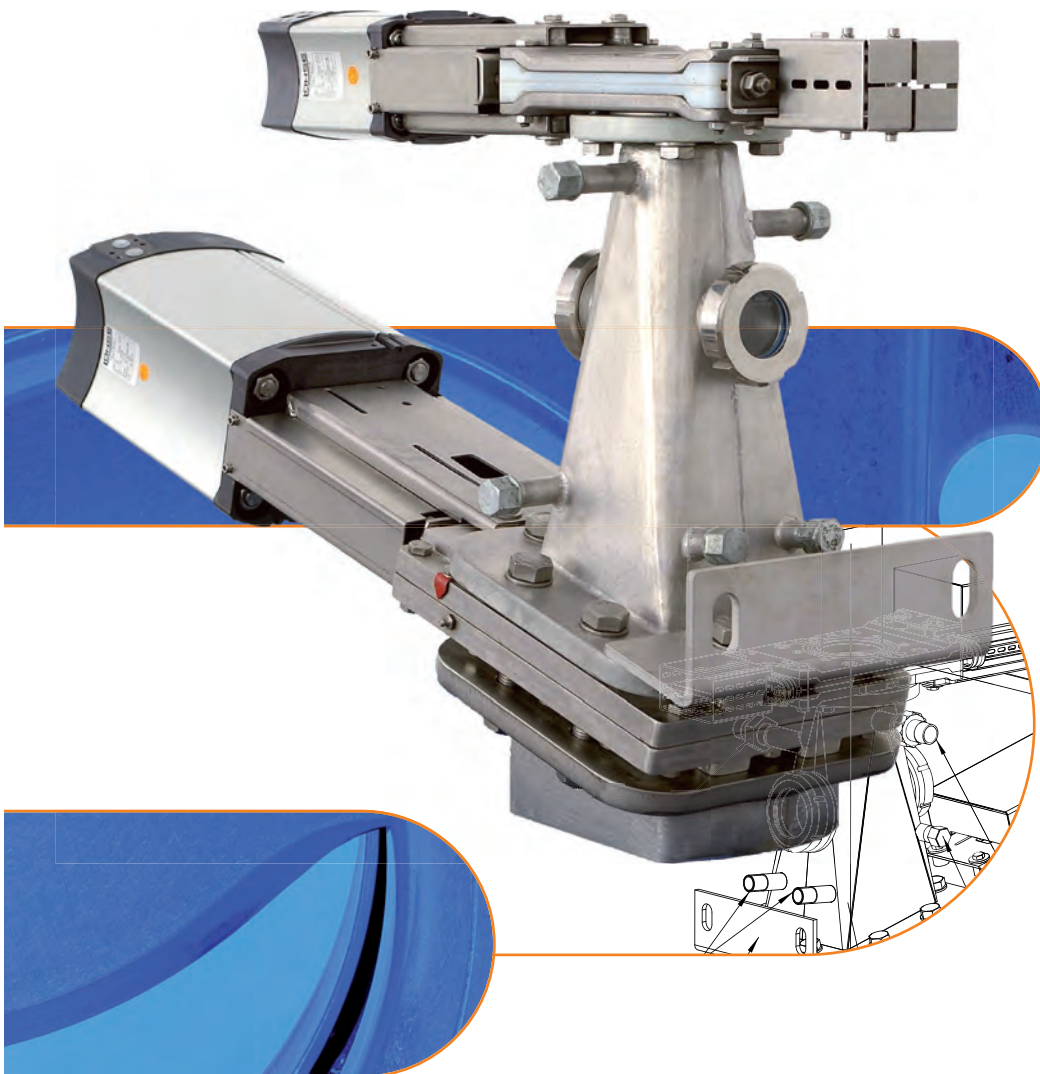

MARTIN LOHSE GmbH
Unteres Paradies 63 · D-89522 Heidenheim
phone +49 7321 755-42
sales@lohse-gmbh.de
www.lohse-gmbh.de

Applications

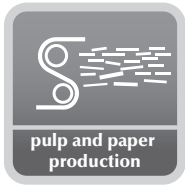

The LOHSE dirt traps RSL have been specially designed for the removal of foreign particles from the cleaning process.

They are used to remove reject particles from fibrous media of various viscosity. They can be used in all types of cleaning machines, tanks and pipelines.

The maximum permissible operating temperature for LOHSE RSL dirt traps is 80 °C / 176° F (dirt traps for higher temperatures are available on request).

The maximum permissible operating pressure for LOHSE RSL dirt traps is 6 bar (dirt traps for higher pressures are available on request).



Media

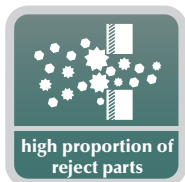

Benefits

- the inclined positioning of the discharge valve prevents the build up of turbulence in the centre of the valve slide plate; as a result there is markedly less wear on the valve slide plate
- the right angular cross section of the discharge valve prevents small parts getting stuck between the valve body and the slide plate
- two back water connections prevent congestion in dead corners
- regulated heavy rejects removal: by means of 2 sight glasses an optimal adjustment of the back water level becomes possible
- pressure relief when at its highest level by means of an air extraction connection
- dirt trap volume can be selected (see list)

Construction

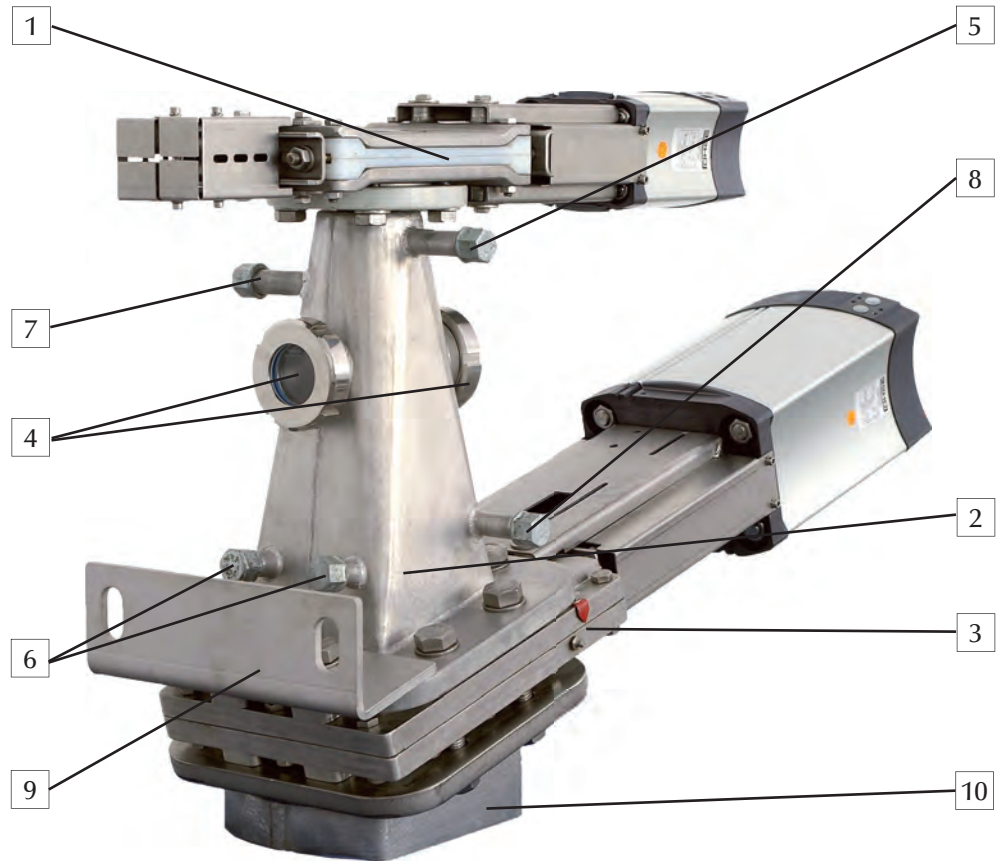

pos.	description	remark
1	inlet valve CDSVP/G	round cross-section
2	sluice chamber	round to rectangular
3	discharge valve AEQP/G	rectangular cross-section
4	sight glasses	
5	air relief C	periodical operating interval
6	cleaning/ filling connections A / B	periodical operating interval
7	flush water connection D	connection recommende by manufacturer
8	flush water connection E	connection recommende by manufacturer
9	attaching device	
10	outlet piece	

Process description

Start of dirt trap control

Power to solenoid valves	„on“
Water pressure	„ok“
Water	„supply ok“
Pump of cleaning machine	„off“
Compressed air for shut-off valve	„supply ok“
- Pressure	„ok“
- Flow control valve	„adjusted“

START – Flushing phase of dirt trap

The moment the pump in front of the cleaning machine is started, the timer relay of the cycle control system is started.

After the cycle time has lapsed:

- Timer relay cycle time	„0“
- Upper shut-off valve	„closed“
- Lower shut-off valve	„open“
- Filling water solenoid valve	„open“
- FILLING timer relay	„on“ (10 to 20 sec.)
- Signal lower valve	„closed“ via exhaust air restrictor
- VENTING timer relay	„on“ (10 to 20 sec.)
- Signal lower valve	„closed“
- FILLING timer relay after time has lapsed	„off“
- Filling water solenoid valve	„closed“
- VENTING timer relay after time has lapsed	„off“
- Air relief solenoid valve	„closed“
- Upper shut-off valve	„open“

If required:

- Readjustment of dilution water by means of manually operated taps	
- Next cycle time started through timer relay	„on“ (5 to 120 minutes)

* All values are approximate and must be adapted to the specific system!

Interlocking:

if there is no compressed air
 if there is no dilution water
 if there is no control voltage
 if there is no medium
 if the medium pressure drops in front of the cleaning machine

Technical data

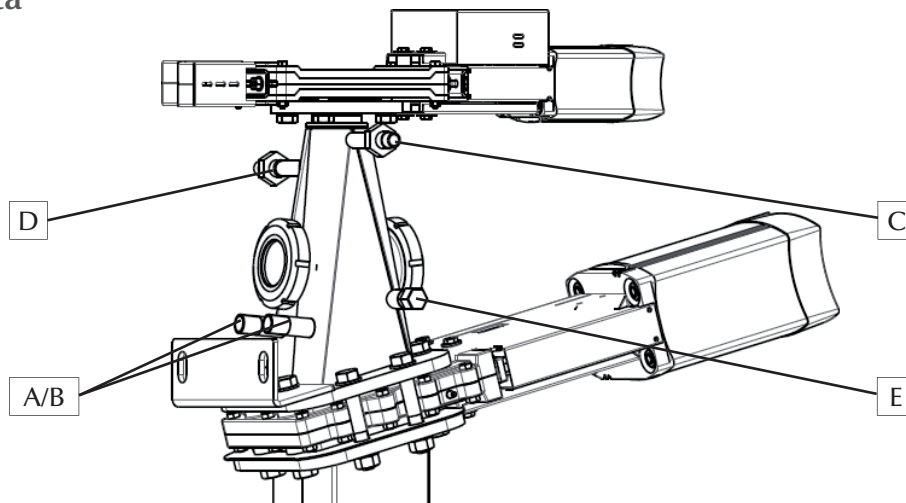

Type	Inlet valve Reject-valve type CDSVP/G	Outlet valve Reject-valve type AEQP/G	Volume ~ [l]	Overall height [mm]	Air relief C [inch]	cleaning/ filling connections A / B [inch]	flush water connect. D [inch]	flush water connect. E [inch]
RSL 50/150	DN 50	DN 150	5	682	1/2	3/4	1/2	3/4
RSL 65/150	DN 65	DN 150	5	682	1/2	3/4	1/2	3/4
RSL 80/150	DN 80	DN 150	5	695	1/2	3/4	1/2	3/4
RSL 100/150	DN 100	DN 150	8	635	1	3/4	1	3/4
RSL 100/200	DN 100	DN 200	11	650	1	3/4	1	3/4
RSL 100/250	DN 100	DN 250	15	634	1	3/4	1	3/4
RSL 125/250	DN 125	DN 250	15	635	1	3/4	1	3/4
RSL 150/200	DN 150	DN 200	13	660	1	3/4	1	3/4
RSL 150/250	DN 150	DN 250	17	662	1	3/4	1	3/4
RSL 200/250	DN 200	DN 250	22	745	1	3/4	1	3/4
RSL 250/300	DN 250	DN 300	40	823	1	3/4	1	3/4
RSL 300/400	DN 300	DN 400	~ 80	985	1	3/4	1	3/4

Outlet valve of grey cast iron (G) or stainless steel (E).

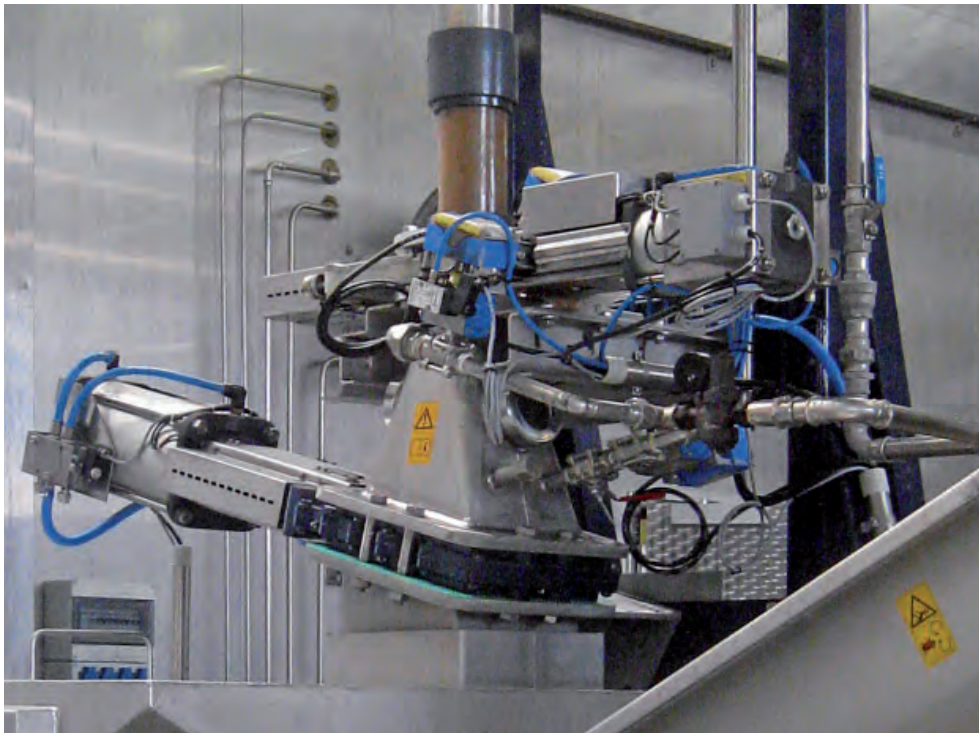
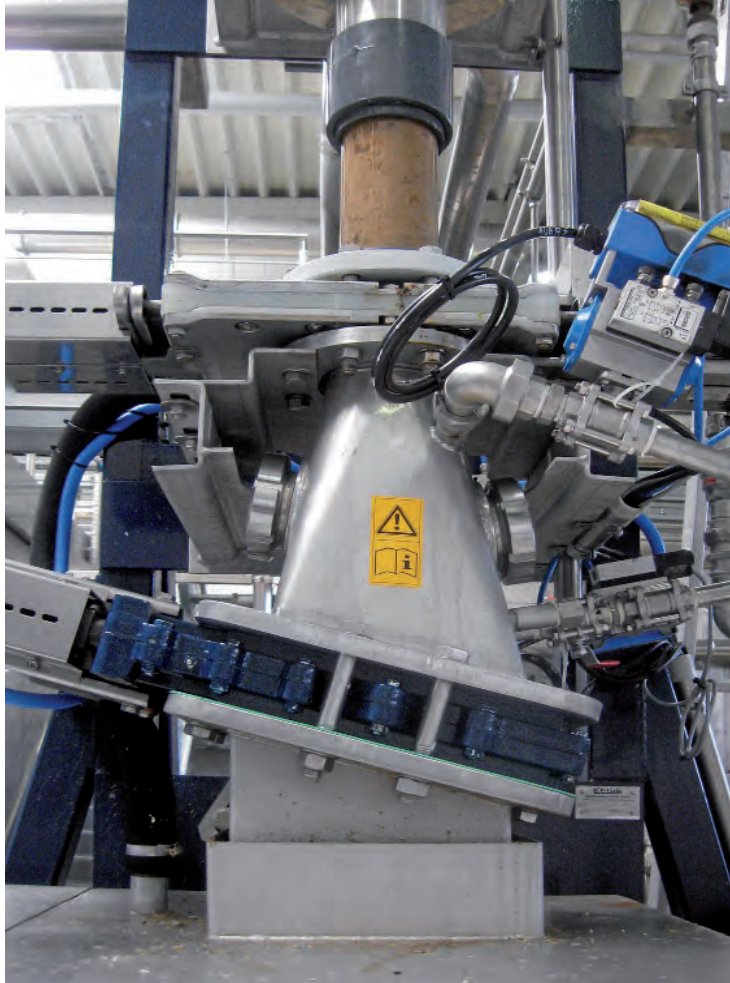

Germany + Switzerland

MARTIN LOHSE GmbH
Unteres Paradies 63
89522 Heidenheim
Phone: +49 7321 755-0
sales@lohse-gmbh.de
www.lohse-gmbh.de

Australia, New Zealand, Indonesia, Singapore, Malaysia

P.T. VOITH PAPER
Jl. Permata V Lot EE - 1
Kawasan Industri KIIC
Karawang 41361, INDONESIA
Phone : +62 267 419 719
Fax : +62 267 419 717

Austria (Papier- + Zellstoffindustrie, Abwasser + Kläranlagen) + CZ, SK, SLO, SRB, HR, H

Peter Rejter
Handel Mazzetti-Str. 85
3100 St. Pölten
Phone: +43 2742 77366
Fax: +43 2742 77366
office@industriearmaturen.at

Austria

Klinger Gebetsroither GmbH & Co KG

Am Kanal 8-10
2352 Gumpoldskirchen
Phone: +43 2252 60 71 00 3029
Fax: +43 2252 60 71 00 3010
gerhard.praxmarer@gebetsroither.at
www.gebetsroither.at

Belgium

Hanwel Belgium N.V.

Winninglaan 15
9140 Temse
Phone: +32 3 7110353
Fax: + 32 3 7110579
info@hanwel.be
www.hanwel.be

Chile

INTERTECH

Prat 116, Of 31
Curicó, Chile
phone +56.075.322033
www.inter-tech.cl
n.flores@inter-tech.cl

People's Rep. Of China

Shanghai Fier Mechanical Co. LTD

Room B4, 15/F HuaFu Bldg.
No. 585 LongHua xi Rd.
ShangHai, China 200232
Phone: +86 21 54591038
Fax: +86 21 54240616
MP: 13611665381
shfier@163.com
www.fier.com.cn

Denmark

Uni-Valve A/S
Sydvestvej 138 – 140
2600 Glostrup
Phone: +45 43 438200
Fax: +45 43 437475
mail@uni-valve.com
www.uni-valve.com

Finland

KLINGER Finland Oy
Tinankuja 3
02430 Masala
Phone: +358 10 4001011
info@klinger.fi
www.klinger.fi

France, MA, TN, DZ T.N.P.

30 Boussegré
58140 Lormes
Phone: +33 1 559711-11
Fax: +33 1 48835207
contact@tnp.fr
www.tnp.fr

Great Britain

Voith Turbo Ltd.
6 Beddington Farm Road
Croydon, Surrey CRO, 4XB
Phone: +44 208 6673013
Fax: +44 208 6670403
matthew.healy@voith.com

Greece

Niko Mikopoulos, BSc.
Metron Str. 28
17123 Nea Smyrni-Athens
Phone: +30 6 98 305 10 70
n.mikopoulos@nm-bc.com

India

Antrieb Technik Private Limited
59 (old 359) Sidco Industrial Estate
Ambattur
Chennai-600 098
Tamilnadu / INDIA
Phone: +91 44 262-58303
Fax: +91 44 2819-3718
antrieb.technik@gmail.com

Israel

P.B.A Wiesner Agencies Ltd.
P. O. Box 4622
Petach-Tikva 49277
Phone: +972 3 9052111
Fax: +972 3 9052110
ofra@pba.co.il

Italy

Techno Paper S.R.L.
Viale Certosa 269
20151 Milano (MI)
Phone: +39 02 78627750
Fax: +39 02 45471638
info@techno-paper.com
www.techno-paper.com

Japan

Voith IHI Paper Technology Co.Ltd.
River City M-SQUARE 7F
2-1-6 Tsukuda, Chuo-ku
1040051 Tokyo
Phone: +81 3 6221 3108
Fax: +81 3 6221 3126

Korea

C.S-Automation Co., Ltd. (Customer Satisfaction Automation)
#804 Sejung Technovalley
279-5 Songjeong-Dong
Heungdeok-Gu
Cheongju-Si
South Korea. 361-290
Phone: +82 43 276 1332
Fax: +82 43 278 1332
changseol@korea.com

Netherlands

Hanwel B. V.
Jan Tinbergenstraat 209
7559 SP Hengelo
The Netherlands
Phone: +31 74 2650000
Fax: +31 74 2650001
verkoop@hanwel.com
www.hanwel.com

Norway

KS Norge AS
Holtbråtveien 69
1449 Drøbak
Phone: +47 917 19995
firmapost@ksb.com
www.ksb.com/en-no

Philippines

R. Dan and Co., Inc.
Lot 6-9 Block 5 Greenway Business
Park
Bulihan, Silang,
Cavite Philippines 4118
Phone: +63 960 690 0244
ester.poe@robertdan.com.ph
www.robertdan.com.ph

Poland

Waldemar Kulicki
ul. Heweliusza 37/4
87-148 Papowo Toruńskie
Phone: +48 509 46 64 25
waldemar-kulicki@wp.pl
www.wkulicki.eu

Rep. of South Africa

Voith Turbo (Pty) Ltd
P.O. Box 13171
Witfield, 1467
Gauteng, SOUTH AFRICA
Phone: +27 11 418 4000
Fax: +27 11 418 4080
info.vtza@voith.com
www.rsa.voithturbo.com

Spain, Portugal

CELPAP EQUIPOS, S.L.
C/Amposta, 14-18
08174 Sant Cugat del Vallés
(Barcelona)
Phone +34 93 415 18 75
celpap@celpap.com
www.celpap.com

Sweden

PA-Ventiler AB
Sagbäcksvägen 3B
43736 Lindome
Phone: +46 31 992500
Fax: +46 31 992503
info@paventiler.se
www.paventiler.se

Switzerland

dampfEXPERTE GmbH
Häsiweg 33
5018 Erlinsbach
Phone: +41 62 5448090
roger.fehr@dampfexperte.ch
www.dampfexperte.ch

Taiwan

E-Chen Engineering Co., Ltd.
3F-3, No. 151, Sec. 4,
Hsin-Yi Road,
Taipei, Taiwan, R.O.C.
Phone: +886 22 7056185
Fax: +886 22 7045967
echen123@ms15.hinet.net

Thailand

Weston Myer Ltd.
8 Soi Seri-Thai 58
Seri-Thai Road
10510 Minburi Bangkok
Phone: +66 2 3745869
Fax: +66 2 375-1179
comm1@westonmyer.com

Turkey

Sanrep Kağıt San. ve Tic. Ltd. Şti.
Altiyol, Kuşdili Caddesi No:19/7
H.Fazlıoğlu İş Merkezi
34714 Kadıköy – İSTANBUL
Phone: +90 216 345 40 48
Fax: +90 216 330 73 12
sanrep@sanrep.com
www.sanrep.com

USA, Canada, Mexico

Voith Paper Inc.
2200 N. Roemer Rd.
Appleton, WI 54912-2237
Phone: +1 920 – 358 – 2396
Fax: +1 920 – 731 – 5126
VPAWSpareParts@voith.com